



853 - COAT

Intermediate

Sizes	S	M	L	XL
Quality DUVETINE Tourterelle 291.041	No. of balls			
	24	27	29	32
6.0 mm & 6.5 mm needles – 1 Cable Needle (cn)				
4 brown fasteners ref 137.401 (pk of 4)				

Abbreviations

K1dbl = place the RH needle in the middle of the st on the row below next st, k1 dropping the st above.

sl1 = sl1 purl-wise with yarn at back of work.

CR = cross Right

CL = cross Left

8CL: slip 4 sts onto cn at front of work, k4, then k4 from cn

3CR2K = sl2 onto cn at back of work, k3, then k2 from cn

3CL2K = sl3 onto cn at front of work, k2, then k3 from cn

3CRP1K1 = sl2 onto cn at back of work, k3, then p1, k1 from cn

3CLK1P1 = sl3 onto cn at front of work, k1, p1, then k3 from cn

3CR2P = sl2 onto cn at back of work, k3, then p2 from cn

3CL2P = sl3 onto cn at front of work, p2, then k3 from cn

3CR3P = sl3 onto cn at back of work, k3, then p3 from cn

3CL3P = sl3 onto cn at front of work, p3, then k3 from cn

Stitches used

BEADED RIB, using 6.0 mm needles. Over an odd number of sts.

Row 1 (RS): k1, *p1, k1*, rep from * to *.

Row 2: p1, *k1dbl, p1*, rep from * to *.

Rep these 2 rows.

PATTERN STITCH, using 6.0 mm needles. Over an odd number of sts.

Row 1 (RS): sl1, *p1, sl1*, rep from * to *.

Row 2: p1, *sl1, p1*, rep from * to *.

Rep these 2 rows.

STOCKING ST & REVERSE ST ST, using 6.5 mm needles.

CABLE A, using 6.5 mm needles. Over 42 sts.

Row 1 (RS): p2, k3, p2, k3, p8, k6, p8, k3, p2, k3, p2.

Row 2 & every WS row: work the sts as they are presented.

Row 3: p2, k3, p2, k3, p6, 3CR2K, 3CL2K, p6, k3, p2, k3, p2.

Row 5: p2, k3, p2, k3, p4, 3CRP1K1, k4, 3CLK1P1, p4, k3, p2, k3, p2.

Row 7: p2, k3, p2, k3, p2, 3CR3P, k6, 3CL3P, p2, k3, p2, k3, p2.

Row 9: p2, k3, p2, k3, 3CR2P, p3, k6, p3, 3CL2P, k3, p2, k3, p2.

Row 11: p2, k3, p2, 3CR3P, p5, k6, p5, 3CL3P, p2, k3, p2.

After Row 12 rep from Row 3.

CABLE B, using 6.5 mm needles. Over 8 sts.

Row 1 (RS): knit.

Row 2 & every WS row: purl.

Row 3: 8CL.

Rows 5, 7, 9 & 11: knit.

After Row 12 rep from Row 3.

1 ST BORDER, using 6.0 mm needles. Over 1 st.

Row 1: p1.

Row 2: sl1.

Rep these 2 rows.

Tension/Gauge

To achieve a good result it is essential to make a tension square (see BASIC knitting instruction pages at beginning of book).

13 sts & 26 rows over Beaded Rib using 6.0 mm needles = 10 cm (4 in) square.

12 sts & 17 rows over St st using 6.5 mm needles = 10 cm (4 in) square.

To make

BACK:

Using 6.0 mm needles CO 87-93-97-103 sts. Work Beaded Rib for 14cm (5 ½ in) [36 rows].

Cont in Pattern St until work measures 17 cm (6 ¾ in) [44 rows] total.

Change to 6.5 mm needles and foll the Chart

according to the size you are making, making 23 increases across the 1st row (see Chart for placing of inc).

Cont on the 110-116-120-126 sts obtained until work measures 22 cm (8 ¾ in) [52 rows] total.

Next row (dec): patt 2, k2tog or p2tog, patt to last 4 sts, sl1, k1, pssso or p2tog, patt 2.

Rep dec row on every 8th row twice, then every 6th row 7 times.

Cont on the rem 90-96-100-106 sts until work measures 59-60-60-61 cm (23 ¼-23 ½-23 ½-24 in) [116-118-118-120 rows] total.

Armholes:

Cast off 1 st at each end of the next row.

Cont on the rem 88-94-98-104 sts until work measures 78-80-82-84 cm (30 ¾-31 ½-32 ¼-33 in) [148-152-156-160 rows] total.

Shoulders & Neck:

Place 28-30-31-33 sts on a spare needle, cast off 32-34-36-38, leave the rem 28-30-31-33 sts on a spare needle.

LEFT FRONT:

Using 6.0 mm needles CO 51-55-57-59 sts, work 50-54-56-58 sts in Beaded Rib, 1 Border St.

This sets the patt cont until work measures 14 cm (5 ½ in) [36 rows].

Next row (RS): Work 40-44-46-48 sts in Pattern st, leave the rem 11 sts on a spare needle.

Work another 7 rows in Pattern St, inc 1 st on the final row for sizes S & XL. (= 41-44-46-49 sts)

Change to 6.5 mm needles and foll the Chart according to the size you are making work 9 inc across the 1st row (see Chart for placing of inc).

Cont on the 50-53-55-58 sts obtained until work measures 22 cm (8 ¾ in) [52 rows], working the dec at the beg of the row as for Back until 40-43-45-48 sts rem.

Cont until work measures 59-60-60-61 cm (23¼-23 ½-23 ½-24 in) [116-118-118-120 rows] total.

Armhole:

Cast off 1 st at beg of next row, then cont on the rem **39-42-44-47** sts until work measures **71-73-75-77** cm (**28-28 ¾-29 ½-30 ¼** in) [**136-140-144-148** rows] total

Neck:

Cast off **5-6-7-8** sts at the beg of next WS row, then cast off 2 sts at beg of foll 2 WS rows, cast off 1 st at beg of foll 2 WS rows.

Cont until work measures **78-80-82-84** cm (**30¾-31 ½-32 ¼-33** in) [**148-152-156-160** rows] total.

Shoulder:

Place the rem **28-30-31-33** sts on a spare needle.

Border:

Using 6.0 mm needles pick up the **11** sts left on a

spare needle, then CO **1** new st on the inside edge of the border for the seam.

On the 12 sts obtained work **11** sts in Beaded Rib, and starting with p1 work **1** Border St.

When Border measures **71-73-75-77** cm (**28-28¾-29 ½-30 ¼** in) total, cast off all the sts.

RIGHT FRONT:

Work as for Left Front reversing all shaping.

SLEEVES:

Started on the WS.

Cuffs:

Using 6.0 mm needles CO **35-37-39-39** sts, work in Beaded Rib for **8** cm (**3 ¼** in) [**19** rows].

The cuffs are completed.

Cont in Beaded Rib starting at Row 1 of the instructions (RS of work).

When work measures **14** cm (**5 ½** in) [**35** rows] total, change to 6.5 mm needles and cont as foll:

Next row: **2-3-4-4** sts St st (inc 1 st on 1st row), 42 sts from Chart, working 10 inc on the 1st row (central sts of the sleeve), **2-3-4-4** sts St st.

Cont on the **46-48-50-50** sts obtained until work measures **19** cm (**7 ½** in) [**43** rows] total.

Next row (inc): inc 1, patt to end, inc 1.

Rep inc row on every foll **8th-8th-8th-6th** row **7-7-2-10** times, then on every **0-0-6th-0** row **0-0-7-0** times.

Cont on the **62-64-70-72** sts obtained until work measures **59** cm (**23 ¼** in) [**111** rows] total, leave the sts on a spare needle.

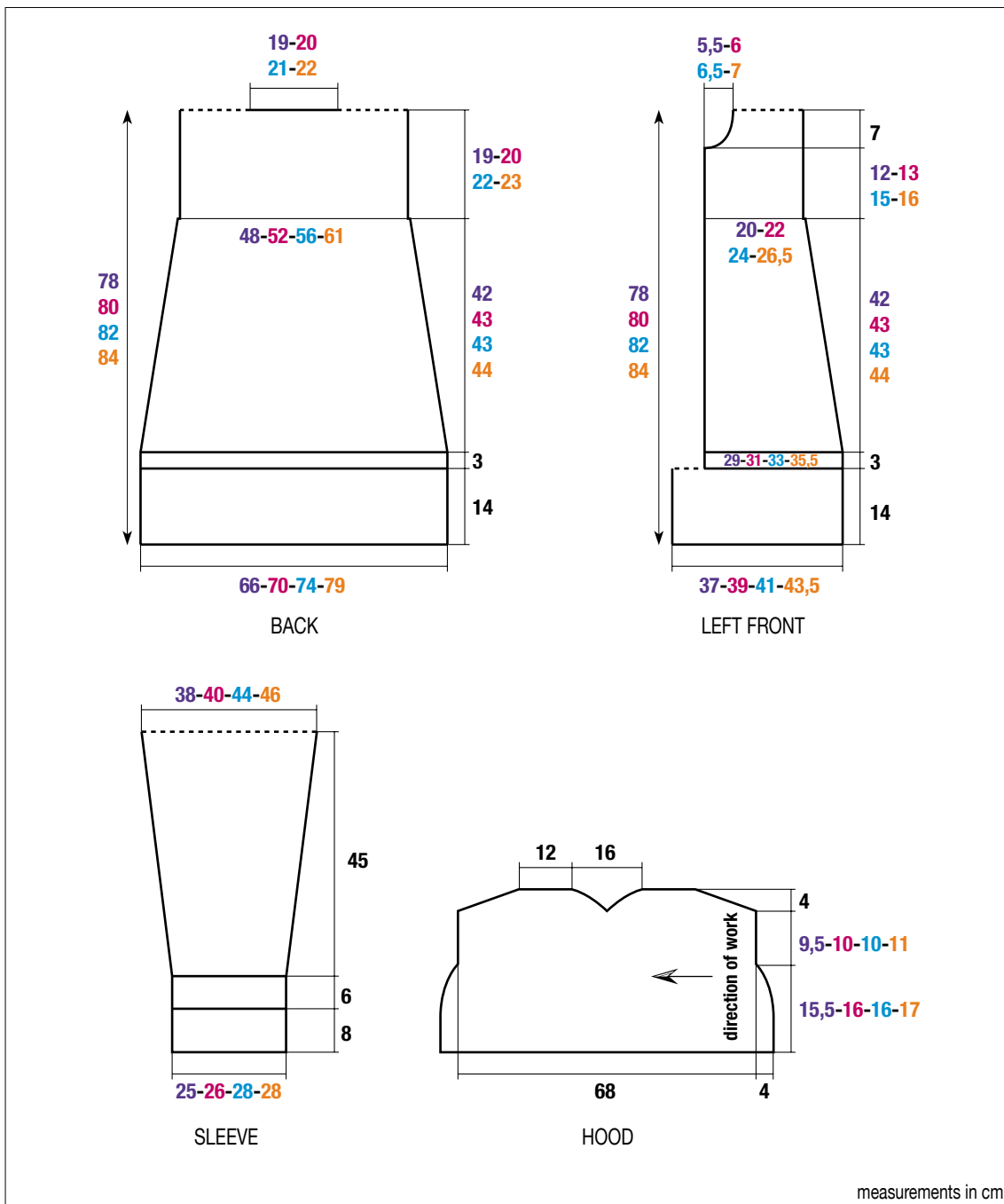

HOOD:

Using 6.0 mm needles CO 15 sts.

Row 1 (RS): work 14 sts Beaded Rib, 1 Border st.

Row 2: 1 Border st, 14 sts Beaded Rib.

Taking extra sts into patt inc at the beg of next and every alt row as foll:

CO on **2 sts 1-2-2-3** times, CO on **1 st 3-2-2-1** times, CO **13-14-14-15** sts once, then CO 1 st at beg of every foll 6th row 6 times.

Cont on the **39-41-41-43** sts obtained until work measures **30 cm (11 ¾ in) [78 rows]** total.

Cast off 1 st at beg of next and every foll 4th row 5 times.

Work 1 row on the rem **33-35-35-37** sts.

Then, inc 1 st at the beg of next and every foll 4th row 5 times.

Cont on the **39-41-41-43** sts obtained until work measures **58 cm (23 in) [152 rows]** total.

Cast off 1 st at beg of next row and every foll 6th row 5 times, cast off **13-14-14-15** sts at beg of foll 6th row, then cast off at beg of every alt row: 1 st **3-2-2-1** times, **2 sts 1-2-2-3** times.

Cast off rem 15 sts.

TO MAKE UP:

Join the Borders to each Front edge.

Join the shoulder seams working a chain on the WS.

Graft the sts from the tops of the sleeves into the armholes (see Grafting a Border instructions).

Stitch the sleeve seams allowing for the cuffs at the bottom of each sleeve.

Turn the cuffs back and hold in place with a couple of sts at the seam.

Sew side seams of the coat.

Fold the hood in half and sew the back seam. Then sew the hood around the neck from the edge of one border to the other.

Fastenings (see photo): Stitch the fastenings (piece with loop on the Right Front): Placing the 1st just below the neck, the 2nd 20 cm from the bottom, space the rem 2 evenly between these.

Secure and weave in all ends.

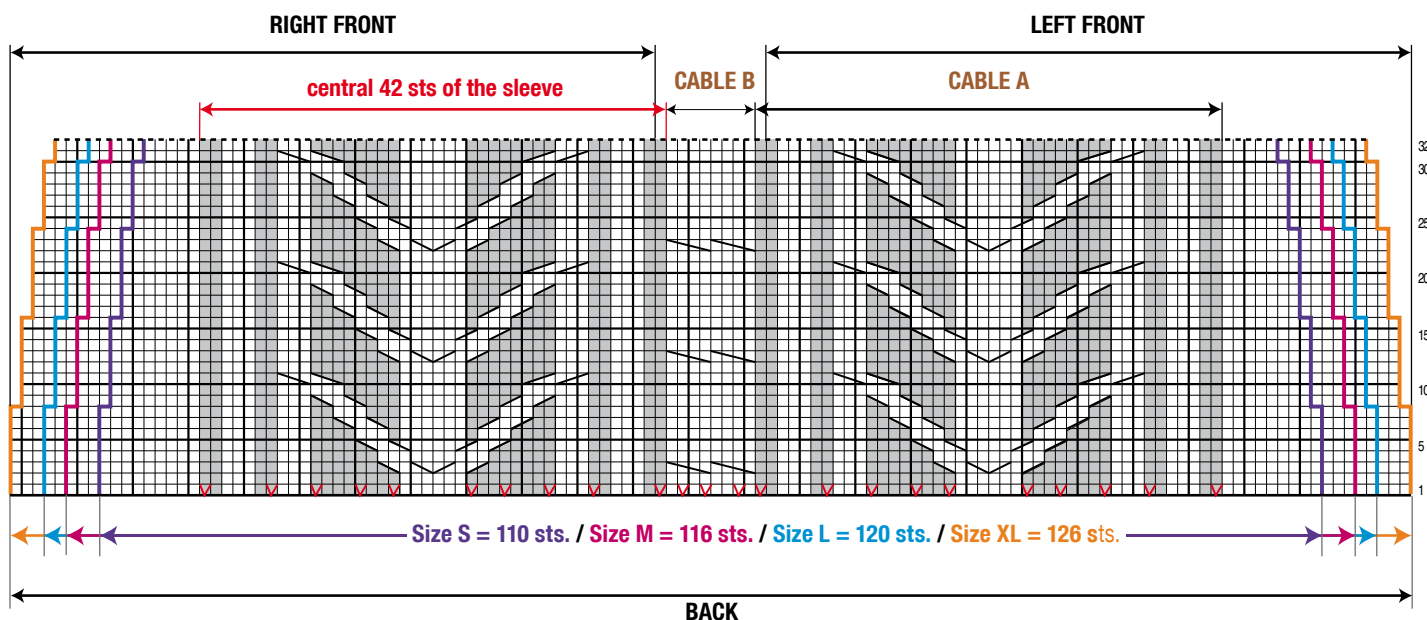

□ = K on WS, P on RS	▨ = 3CRP1K1
▣ = P on RS, K on WS	▩ = 3CLK1P1
⊠ = inc 1	▧ = 3CR2P
▤ = 3CR2K	▦ = 3CL2P
▥ = 3CL2K	▨ = 3CR3P
▧ = 8CL	▩ = 3CL3P